

# SPECTRO Series

## ► SPECTRO-3-POF-MSM-ANA-DL

- **Color control** (color, contrast, and gray scale detection)
- Big assortment of plastic optic fibers of POF Series available (reflected light fiber optics and transmitted light fiber optics)
- Working distance in reflected light operation typ. 1 mm ... 100 mm  
Working distance in transmitted light operation typ. 1 mm ... 500 mm (depends on the fiber optics type used)
- $L^*a^*b^*$ ,  $L^*C^*h^*$ ,  $L^*u^*v^*$ ,  $L^*u^*v'$  and xyY evaluation (CIE standard)
- Up to 3 colors can be stored
- D65-similar LED light source,  
AC- or DC-operation can be switched
- Insensitive to outside light (in AC-operation)
- Scan frequency max. 90 kHz (in DC-operation)
- Switching frequency typ. 60 kHz
- 3 analog outputs to output color values to PLC
- 2 digital outputs to output taught colors
- TEACH via PC or PLC (external input)
- Various evaluation algorithms can be activated
- "BEST HIT" mode ("human color assessment")
- Averaging can be activated (from 1 up to over 32000 values)
- Parameterizable via Windows® software, scope function
- RS232 interface (USB or Ethernet converter available)
- Temperature compensated
- Color measurement of luminous objects (LEDs, halogen lamps, displays, ...)
- 3-color filter detector (true color detector: "human color perception")
- Transmitted light evaluation

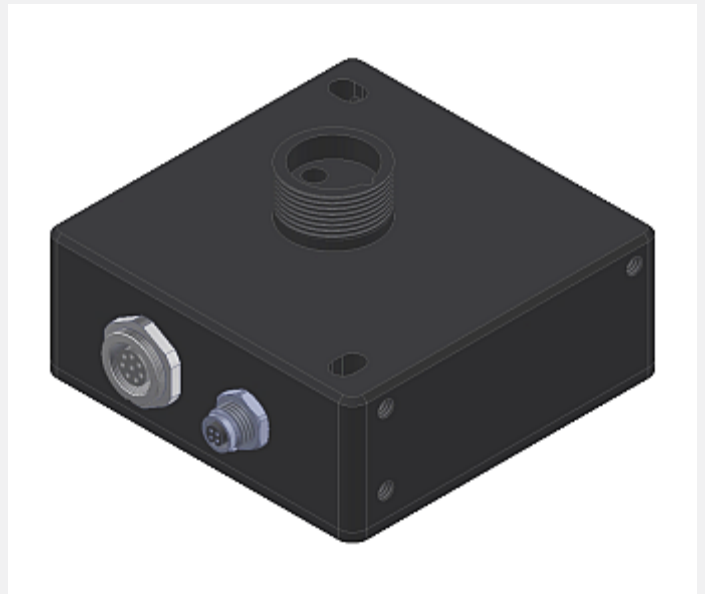

## Design

### Product name:

### SPECTRO-3-POF-MSM-ANA-DL

(incl. Windows® software  
SPECTRO3-MSM-ANA-Scope)

### Accessories: (p. 8-9)

### Fiber optics: POF Series

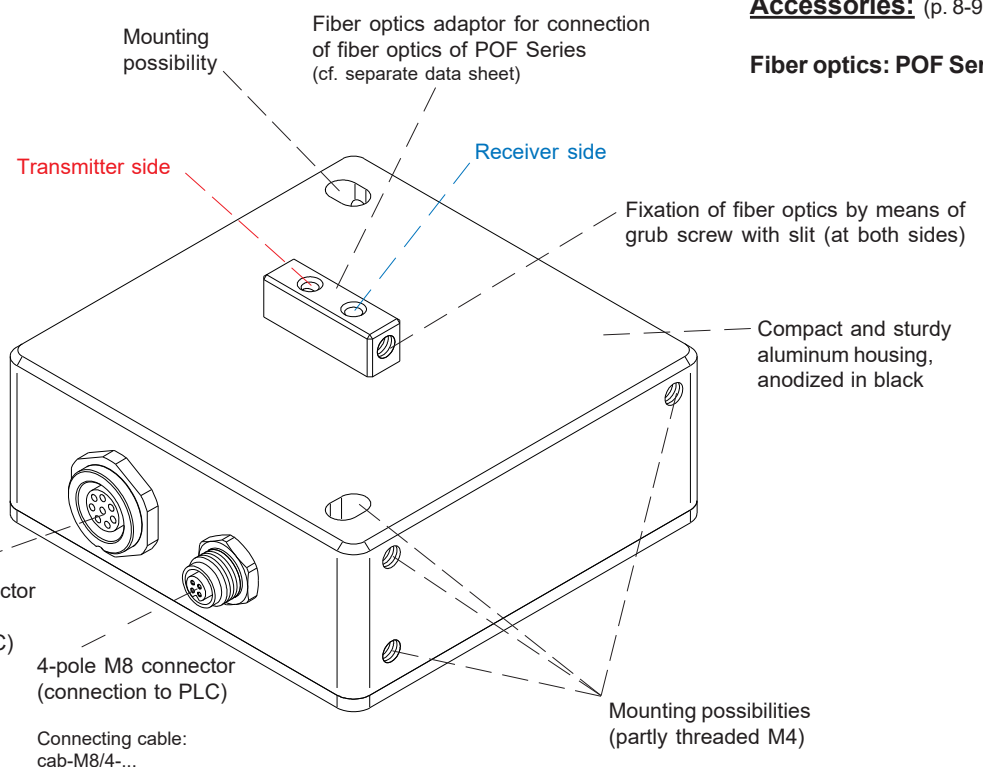

8-pole fem. connector  
Binder Series 712  
(connection to PLC)

Connecting cable:  
cab-las8/SPS

4-pole M8 connector  
(connection to PLC)

Connecting cable:  
cab-M8/4-...

Mounting possibilities  
(partly threaded M4)

Sensor  
Instruments



**Technical Data**

Type	SPECTRO-3-POF-MSM-ANA-DL
Voltage supply	+24VDC ( $\pm 10\%$ ), reverse polarity protected, overcurrent protected
Current consumption	< 160 mA
Max. switching current	100 mA, short circuit proof
Input digital (1x)	IN0 (Pin 3), digital (0V/+24V)
Outputs digital (2x)	OUT0, OUT1 (Pin 4 and 5): digital (0V/+24V), npn-/pnp-able (bright-/dark-switching, can be switched)
Outputs analog (3x)	OUT2, OUT3, OUT4 (Pin 6, 7, and 8): 0...+10V or 4...20mA (xyY, a*b*L*; u*v*L*, u'v'L*, C*h*L*, XYZ)
Interface	RS232 (an external USB and ETHERNET converter is available)
Pulse lengthening	0 ... 100 ms, adjustable via PC software
Averaging	max. 32768 values, adjustable via PC software
Scan frequency	LED operation, can be switched via PC software: AC operation: max. 25 kHz (depends on parameterization) DC operation: max. 90 kHz (depends on parameterization)
Switching frequency	typ. 60 kHz
Analog band width	max. 90 kHz (-3dB)
Transmitter (light source)	LED with spectral characteristics similar to D65
Transmitter control	can be switched via PC software: AC operation (LED MODE-AC), DC operation (LED MODE-DC)
Object distance (working range)	with reflected light fiber optics: typ. 1 mm ... 100 mm (depends on selected fiber optics of POF Series) with transmitted light fiber optics: typ. 1 mm ... 500 mm (depends on selected fiber optics of POF Series)
Receiver	3-color filter detector (TRUE COLOR detector, "human color perception"), color filter curves acc. to CIE 1931
Receiver gain setting	8 steps (AMP1 ... AMP8), adjustable via PC software
Ambient light	max. 5000 Lux
Size of light spot	typ. $\varnothing$ 1 mm ... $\varnothing$ 20 mm (depends on selected fiber optics of POF series)
Reproducibility	in the X, Y color range each 1 digit at 12-bit A/D conversion
Temperature drift X,Y	$\Delta X/\Delta T$ ; $\Delta Y/\Delta T$ typ. 0,2 digits/ $^{\circ}$ C (< 0,01% / $^{\circ}$ C)
Measurement accuracy	typ. $\Delta E = 0.3$
Resolution	$\Delta E \geq 0.01$ in case of color space L*u*v': $\Delta u'v' = 0.001$
Color space	CIE L*a*b*, CIE L*C*h*, CIE L*u*v*, CIE L*u'v', and CIE xyY
Color memory capacity	non-volatile EEPROM with parameter sets for max. 3 colors
Housing dimensions	LxWxH approx. 65 mm x 65 mm x 32.5 mm (incl. adaptor for plastic optic fibers, without flange connectors)
Housing material	aluminum, anodized in black
Enclosure rating	IP64
Connecting cables	to PLC: cab-las8/SPS or cab-las8/SPS-w to PC/RS232 interface: cab-las4/PC or cab-las4/PC-w to PC/USB interface: cab-4/USB or cab-4/USB-w to PC/Ethernet interface: cab-4/ETH
Type of connector	connection to PLC: 8-pole fem. connector (Binder 712), connection to PC: 4-pole fem. connector (Binder 707)
Operating temp. range	-20 $^{\circ}$ C ... +55 $^{\circ}$ C
Storage temperature range	-20 $^{\circ}$ C ... +85 $^{\circ}$ C
EMC test acc. to	DIN EN 60947-5-2

Dimensions

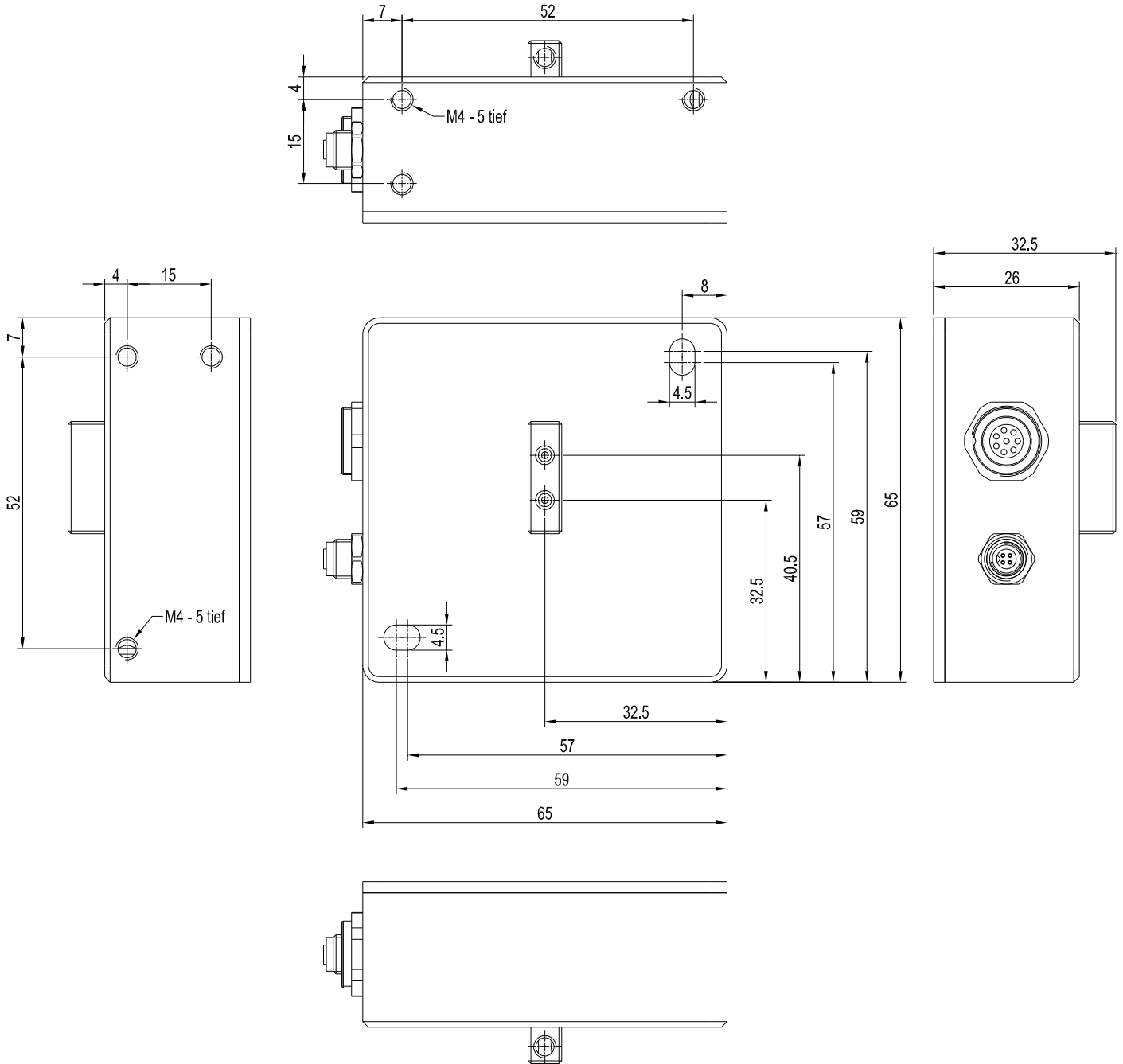

All dimensions in mm



 Connector Assignment

**Connection to PLC:**
**8-pole fem. connector Binder series 712**

Pin:	Color:	Assignment:
1	white	GND (0V)
2	brown	+24VDC ( $\pm 10\%$ )
3	green	IN0 (Digital 0: 0 ... 1V, Digital 1: +Ub - 10%)
4	yellow	OUT0 (Digital 0: 0 ... 1V, Digital 1: +Ub - 10%)
5	grey	OUT1 (Digital 0: 0 ... 1V, Digital 1: +Ub - 10%)
6	pink or black	OUT2 X, x, a*, u*, u' or C* (Analog: 0 ... +10V or 4 ... 20mA)
7	blue	OUT3 Y, y, b*, v*, v' or h* (Analog: 0 ... +10V or 4 ... 20mA)
8	red	OUT4 Z, Y or L* (Analog: 0 ... +10V or 4 ... 20mA)

**Connecting cable:**

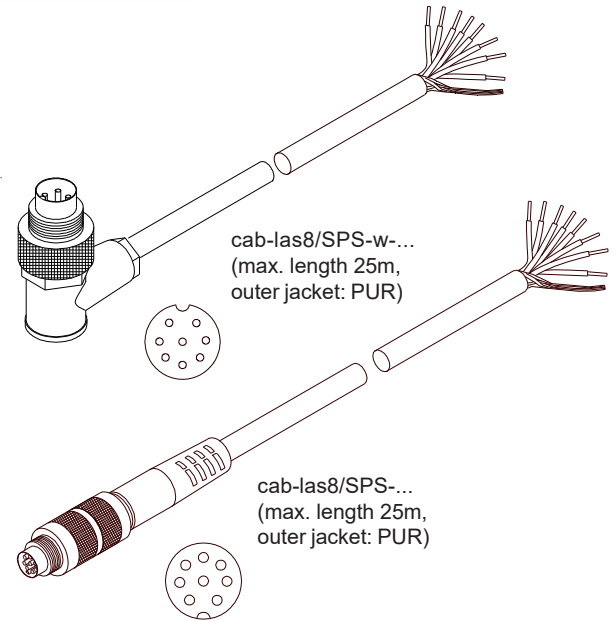
cab-las8/SPS-(length)  
 cab-las8/SPS-w-(length)  
 (standard length 2m)

**Connection to PC:**
**4-pole fem. connector Binder Series 707**

Pin:	Assignment:
1	+24VDC (+Ub, OUT)
2	GND (0V)
3	RxD
4	TxD

**Connection via RS232 interface at the PC:**

**Connecting cable:**  
 cab-las4/PC-(length)  
 cab-las4/PC-w-(length) (angle type 90°)  
 (standard length 2m)

**alternative:**
**Connection via USB interface at the PC:**

**USB converter (incl. driver software):**  
 cab-4/USB-(length)  
 cab-4/USB-w-(length) (angle type 90°)  
 (standard length 2m)

**alternative:**
**Connection to local network via Ethernet bus:**

**Ethernet converter (incl. software „SensorFinder“):**  
 cab-4/ETH-500  
 (standard length 0.5m)

**Optional: External CAT5 cable, e.g.**

cab-eth/M12D-RJ45-flx-(length)

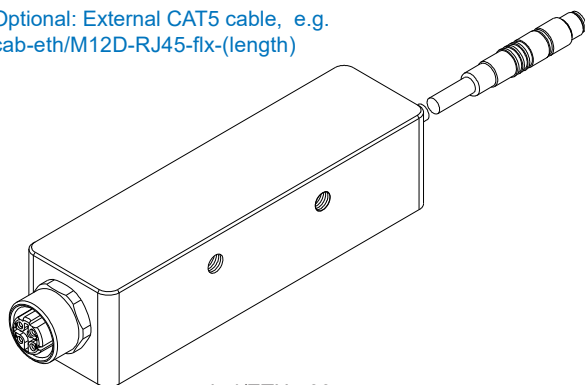
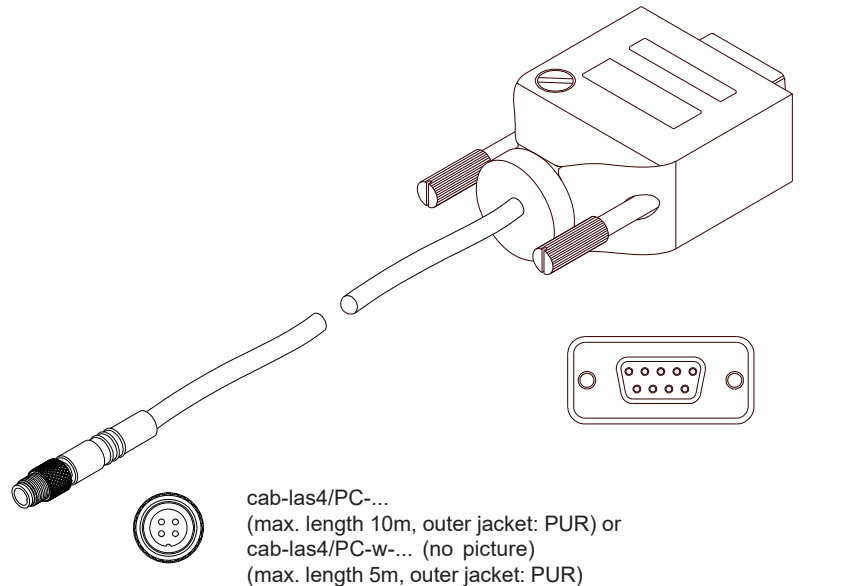

cab-4/ETH-500  
 (length 0.5m, outer jacket: PUR)  
 4-pole M12 fem. conn. (D-coded)  
 for connection of an external  
 CAT5 cable, e.g.  
 cab-eth/M12D-RJ45-flx-(length)

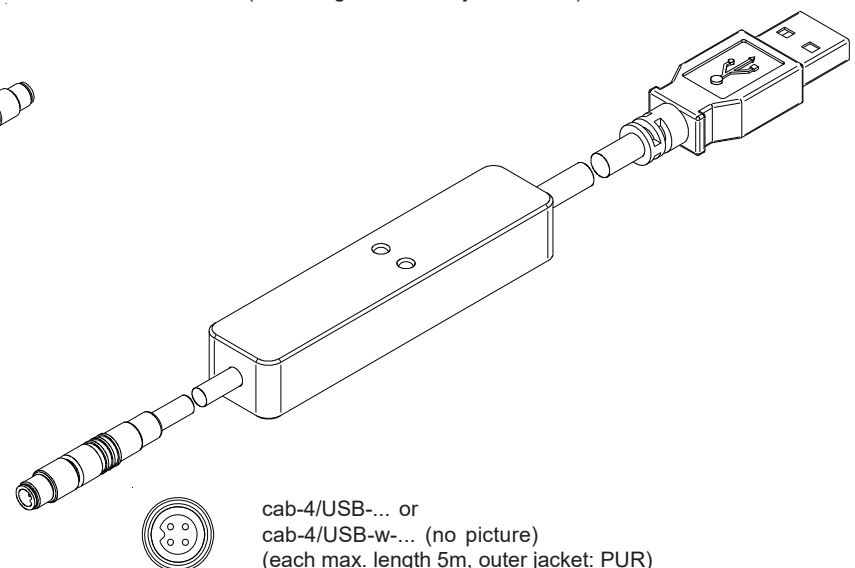

cab-4/USB-... or  
 cab-4/USB-w-... (no picture)  
 (each max. length 5m, outer jacket: PUR)

**Measuring Principle****Measuring principle of color sensors of SPECTRO-3-...-MSM-ANA Series:**

The SPECTRO-3-MSM-ANA color sensor provides highly flexible signal acquisition. For example, the sensor can be operated in alternating-light mode (AC mode), which makes the sensor insensitive to extraneous light. It also can be set to constant-light mode (DC mode), which makes the sensor extremely fast. With the stepless adjustment of the integrated light source as well as the selectable gain of the receiver signal and an INTEGRAL function the sensor can be set to almost any surface or any "self-luminous object".

When the integrated light source of the SPECTRO-3-MSM-ANA color sensor is activated, the sensor detects the radiation that is diffusely reflected from the object. As a light source the SPECTRO-3-MSM-ANA color sensor uses LEDs (in case of color sensor type -VISUV additional UV LEDs) with adjustable transmitter power. An integrated 3-fold receiver for the red, green, and blue content of the light that is reflected from the object, or the light that is emitted by a "self-luminous object", is used as a receiver.

The SPECTRO-3-MSM-ANA color sensor can be "taught" up to 3 colors. For each of these taught colors it is possible to set tolerances. Evaluation of the taught colors is performed either with the "FIRST HIT" or with the "BEST HIT" mode. With "FIRST HIT" the first hit in the teach table is output, and with "BEST HIT" the best hit in the teach table is output. Raw data are represented with 12 bit resolution.

Color detection either operates continuously or is started through an external PLC trigger signal. The respective detected color either is provided as a binary code at the 2 digital outputs or can be sent directly to the outputs, if only up to 2 colors are to be detected.

In addition to the 2 digital outputs there also are 3 analog outputs that either provide the red, green, and blue components or the calculated color coordinates in values of 0...+10V or 4...20mA.

Through input IN0 (green wire of the cab-las8/SPS cable) the color sensor can be taught up to 3 colors. For this purpose the corresponding parameter mode must be set with the software.

Parameters and measurement values can be exchanged between a PC and the SPECTRO-3-MSM-ANA color sensor through the serial RS232 interface. All the parameters for color detection also can be saved to the non-volatile EEPROM of the SPECTRO-3-MSM-ANA color sensor through this serial RS232 interface. When parameterisation is finished, the color sensor continues to operate with the current parameters in STAND-ALONE mode without a PC.

Possible firmware updates can be easily performed through the RS232 interface, even with the sensor system in installed condition. (a firmware update is performed via the software „FirmwareLoader“).

The measuring sensors of the SPECTRO-3-MSM-ANA series are factory calibrated. When establishing the connection, the date of the next calibration is displayed in the status window in the CONNECT tab. For continuously accurate measurement results, we recommend having the calibration renewed every 12 months and sending in the sensors for calibration.

Moreover, the sensors of the SPECTRO-3-MSM-ANA series can be individually calibrated. Calibration can be performed to any surface with known color coordinates. A ColorChecker™ table is available as an alternative. This table has 24 color fields according to the CIE STANDARD that can be used for calibration.

Furthermore, input IN0 can be used for performing white light balancing.

## Parameterization

**Windows® user interface:**

(The current software version is available for download on our website.)

The color sensor is parameterized under Windows® with the SPECTRO3-MSM-ANA-Scope software. The Windows® user interface facilitates the teach-in process at the color sensor and supports the operator in the task of adjustment and commissioning of the color sensor.

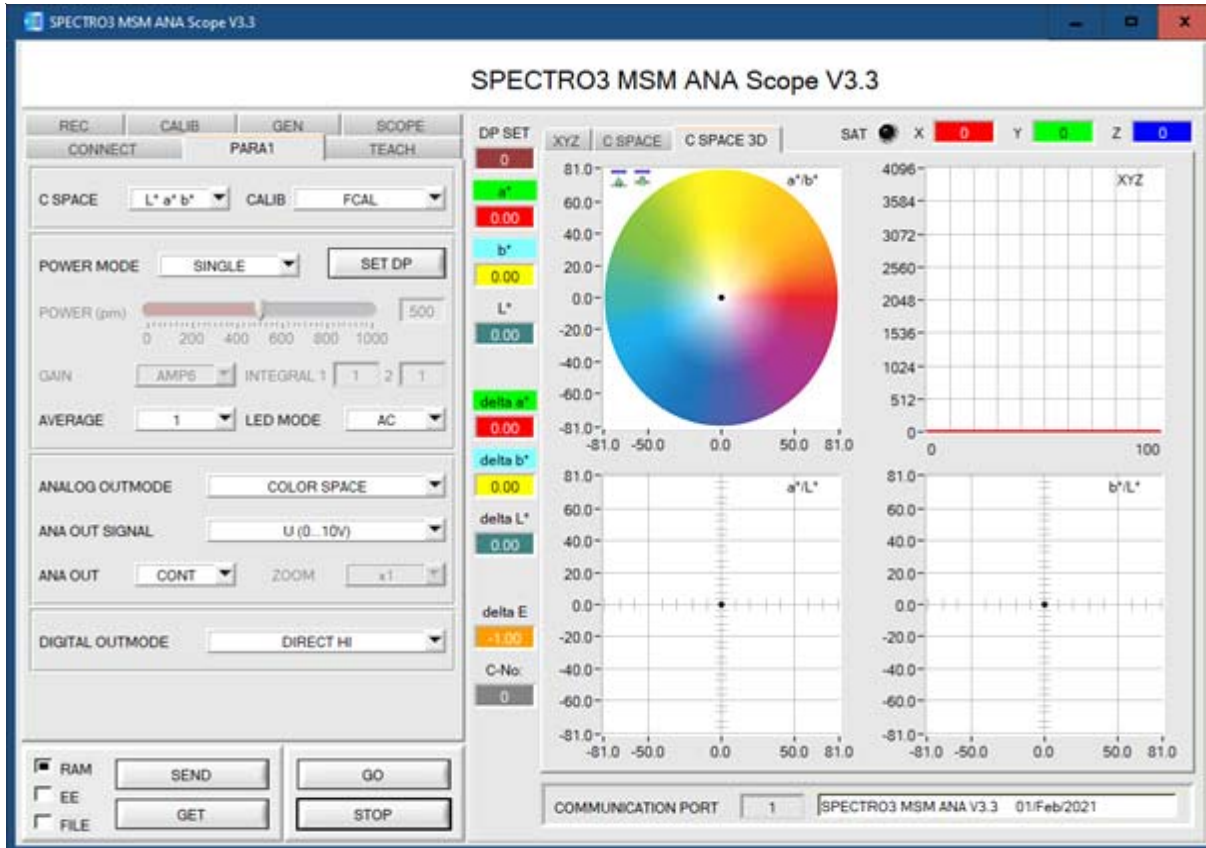

The RS232 interface (tab PARA1) is used for setting parameters such as e.g.:

- POWER MODE (SET DP): Light power of the LED (Set Double Parameter)
- LED MODE: Triggering of the internal light source (AC, DC)
- GAIN: Used for setting the gain of the receiver (AMP1 ... AMP8)
- AVERAGE: Averaging over a maximum of 32768 values. This function field is used for adjusting the number of scanning values (measurement values) over which the raw signal measured at the receiver is averaged. A higher AVERAGE default value reduces noise of the raw signals at the receiver unit and there will be a decrease of the maximal available switching frequency of the sensor
- INTEGRAL: This function field is used to set the number of scan values (measurement values) over which the raw signal measured at the receiver is summed up. This integral function allows the reliable detection even of extremely weak signals
- C SPACE: Selection of a color space ((L\*a\*b\*, L\*C\*h\*, L\*u\*v\*, L\*u'v', or xyY) for the calculation of the color stimulus specification
- ANALOG OUTMODE: Function to determine the signals that the sensor provides at its analog outputs (OUT2, OUT3, OUT4) (OFF, XYZ, COLOR SPACE, CS REF)
- EVALUATION MODE: BEST HIT or FIRST HIT
- TRIGGER: Continuous or external or self trigger (CONT, EXT1, EXT2, TRANS)
- EXTEACH: In all the evaluation modes teaching of a color can be performed externally through IN0.
- INTLIM: Minimum intensity required for color evaluation
- MAXCOL-No.: Number of colors to be checked
- DIGITAL OUTMODE: Control of the two digital outputs (OUT0, OUT1)
- Tab TEACH: Opens a window where you can teach colors to the TEACH TABLE
- Tab CALIB: Selection of calibration mode (FCAL = factory calibration or UCAL = user calibration).
- Tab SCOPE: Visualises an oscilloscope
- Tab GEN: Displays the current temperature value TEMP in the sensor housing
- Tab REC: Data recorder



## Firmware Update

### Windows® software „FirmwareLoader“:

(The current software version is available for download on our website.)

The software „Firmware Loader“ allows the user to perform an automatic firmware update. The update will be carried out through the RS232 interface.

An initialisation file (xxx.ini) and a firmware file (xxx.elf.S) are required for performing a firmware update. These files can be obtained from your supplier. In some cases an additional firmware file for the program memory (xxx.elf.p.S) is also needed, and this file will be automatically provided together with the other two files.

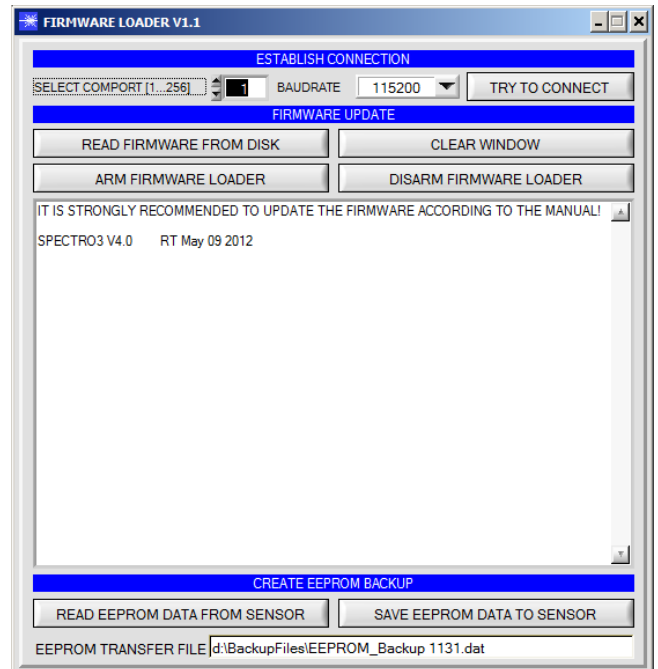

## Monitoring Software

### Windows® software „SPECTRO3-MSM-ANA-Monitoring“:

(The current software version is available for download on our website.)

The software „SPECTRO3-MSM-ANA-Monitoring“ was developed for configuring up to 8 color sensors of the SPECTRO-3-MSM-ANA series in a multi-sensor system that can be used for the continuous inline measurement and control of surfaces at several measuring points at the same time.

Measurement values are recorded and are also displayed at the PC monitor, and they can be printed out after the end of recording.

The software concept provides two user levels: A password-protected administrator function for configuring the inline measurement system and for setting all the parameters for operation, and an easy-to-use user function that only allows the setting of the start and end of recording with input of production parameters (that have been determined by the administrator). The print function also is available for the normal user.

As a support for commissioning and operation of the SPECTRO3-MSM-ANA-MONITORING software this manual explains the individual functional elements of the graphic Windows® user interface.

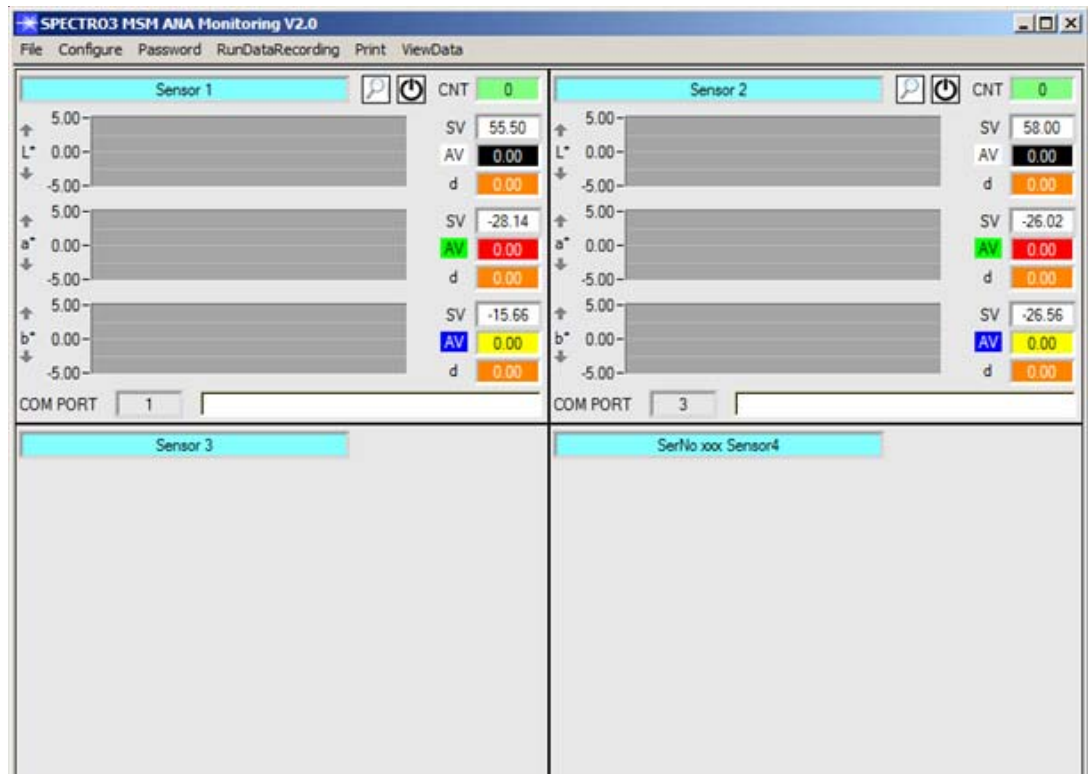



## Plastic Optic Fibers

# POF Series

## Plastic Optic Fibers

The plastic optic fibers of POF Series are used for **contactless detecting, counting, controlling, positioning** as well as **scanning of micro objects at processing stations, feed and automatic systems.**

- Big assortment of sensors (diffuse reflection or through-beam)
- Small sensing heads with different lines of sight (axial, angular, flexible)
- Trouble-free shortening of the plastic optic fibers
- Small bending radius, low weight
- Possible application in explosion-hazardous areas
- No interference by magnet or high-frequency fields (welding plants, switchgear et al.)
- Sturdy, flexible, vibration-proof
- For temperatures from -55°C to +80°C (or +350°C with HT type)



### Characteristics:

Our plastic optic fiber systems consist of an optoelectronic fiber optic sensor (e.g. SPECTRO-1-POF, SPECTRO-1-POF-IR, SPECTRO-3-POF-SL, SPECTRO-3-POF-SLA, SPECTRO-3-POF-SLE) and a flexible plastic optic fiber with a sensing head.

The principle of operation is similar to a through-beam sensor or a diffuse reflection sensor.

The optoelectronic fiber optic sensor includes transmitter, receiver, evaluation electronics and amplifier. It uses e.g. white light or IR light, which is transmitted through the fiber by the principle of total internal reflection (see figure "reflection inside a plastic optic fiber").

We offer a wide choice of sensing heads that can be adapted to suit varying field conditions. E.g. as a diffuse reflection sensor or as a through-beam sensor with axial or radial light emission or with a 90mm flexible stainless steel sleeve which is even capable of „looking“ round corners, if needed.

The advantages of plastic optic fibers are the small bending radii. The fiber optics are bendable in any directions within the stated bending radii. It is also possible to cut the fibers in the field to any desired length using the fiber cutting tool (POF-CUTTER).

### Order code:

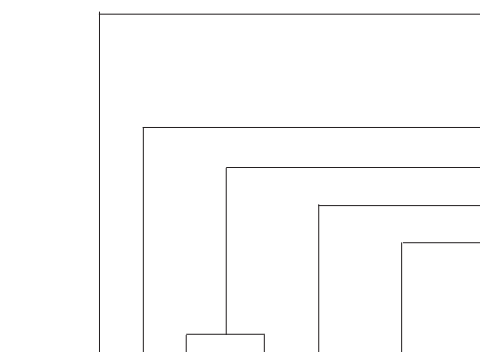

**POF-D-80-d2.5/d1-(0.5)-2000**

Order code plastic optic fibers (example)

(For detailed description of the various types of plastic optic fibers, please cf. catalog „POF Series“)

### Function principle of the plastic optic fiber

(D = through-beam operation, D/90 = through-beam operation, angular 90°

R = reflective light operation, R/90 = reflective light operation, angular 90°)

**Working range (scanning range)** (in mm)

**Sensor head type** (e.g. d2.5/d1 = sensor head case style Ø 2.5mm and Ø 1mm)

**Cross section of fiber bundle** (in mm)

**Total length of optic fiber** (in mm)

Special versions:

**-HT:** Sensor head for use in applications with high temperature (up to 350°C)

**-VA:** Stainless steel sheathing (VA / SUS) of the optical fibers

**-CSC:** Cross section converter

**-SPX:** Simplex (plastic optic fiber in simple version without a sensor head)





(For detailed description of the various types of plast optic fibers, please cf. catalog „POF Series“)

#### Diffuse reflection sensors:

##### Reflected light optical fibers - optics axial ..... Catalog

POF-R-12-18x14x6-(0.5)-2000 .....	Page 4
POF-R-25-d4/d1.5-(1.1)-1000 .....	Page 4
POF-R-30-M6x0.75/d2.5-(1.0)-2000 .....	Page 5
POF-R-32-d3-(0.5)-2000 .....	Page 5
POF-R-32-M4/M3-(0.5)-2000 .....	Page 6
POF-R-35-d4/d3-(0.5)-2000 .....	Page 6
POF-R-35-M4/d3-(0.5)-2000 .....	Page 7
POF-R-40-M6x0.75/d4-(1.0)-2000 .....	Page 7
POF-R-45-M4/d2.5-(0.5)-2000 .....	Page 8
POF-R-55-M4/M3-(0.5)-2000 .....	Page 8
POF-R-60-M5x0.5-(0.5)-2000 .....	Page 9
POF-R-75-d6/d4-(1.0)-2000 .....	Page 9
POF-R-75-M6/d4.5-(1.0)-2000 .....	Page 10
POF-R-90-M4-(1.0)-2000 .....	Page 10
POF-R-110-20x20x5-(1.1)-2000 .....	Page 11
POF-R-110-d3-(1.0)-2000 .....	Page 11
POF-R-110-M6/d2.5-(1.1)-2000 .....	Page 12
POF-R-125-M3/d2-(0.5)-2000 .....	Page 12

POF-R-125-M4/d2.5-(0.5)-2000 .....	Page 13
POF-R-220-M6-(1.1)-2000 .....	Page 13
POF-R-230-15x9.5x5.2-(1.1)-2000 .....	Page 14
POF-R-400-M6/d4.5-(1.0)-2000 .....	Page 14

##### Reflected light optical fibers - high temperature resistant

POF-R-HT-M6x0.75/d4-(1.0)-2000-VA .....	Page 15
---	---------

##### Reflected light optical fibers - optics lateral 90°

POF-R/90-12-24x21x4-(0.5)-2000 .....	Page 16
POF-R/90-25-d3/d1.5-(0.5)-2000 .....	Page 16
POF-R/90-45-d5/d2-(1.1)-2000 .....	Page 17
POF-R/90-85-M8/d4-(1.0)-2000 .....	Page 17

##### Reflected light optical fibers „simplex“

POF-SPX1-d2.2-(1.0)-(length) .....	Page 18
------------------------------------	---------

#### Through-beam sensors:

##### Through-beam optical fibers - optics axial

POF-D-40-d1-(0.5)-500 .....	Page 19
POF-D-80-15x15x5-(0.5)-2000 .....	Page 19
POF-D-100-d3/d1.5-(0.5)-2000 .....	Page 20
POF-D-100-d4/d3-(0.5)-2000 .....	Page 20
POF-D-100-M3/d2-(0.5)-2000 .....	Page 21
POF-D-100-M4/d1.2-(1.0)-2000 .....	Page 21
POF-D-120-M4/M2.6-(1.0)-2000 .....	Page 22
POF-D-140-d1.5-(0.5)-2000 .....	Page 22
POF-D-140-M3/d0.88-(0.5)-2000 .....	Page 23
POF-D-140-M3/d2-(0.5)-2000 .....	Page 23
POF-D-140-M4/M2.6-(1.0)-2000 .....	Page 24
POF-D-200-M4/d3-(1.0)-2000 .....	Page 24
POF-D-290-d3/d2-(1.1)-2000 .....	Page 25
POF-D-400-M4/d1.48-(1.0)-2000 .....	Page 25
POF-D-440-M4/d3-(1.0)-2000 .....	Page 26
POF-D-530-M4/M2.6-(1.0)-2000 .....	Page 26
POF-D-800-d2.5-(1.0)-2000 .....	Page 27
POF-D-1400-12x8x3-(0.5)-2000 .....	Page 27
POF-D-14000-M14-(1.0)-10000 .....	Page 28

##### Through-beam optical fibers - optics lateral 90°

POF-D/90-100-d4-(1.0)-2000 .....	Page 28
POF-D/90-180-d2/d1-(1.0)-2000 .....	Page 29
POF-D/90-200-d2.5/d1.5-(1.0)-2000 .....	Page 29
POF-D/90-200-M4/d3-(1.0)-2000 .....	Page 30
POF-D/90-230-M4/M2.6-(1.0)-2000 .....	Page 30
POF-D/90-350-69x20x5-(1.1)-2000 .....	Page 31
POF-D/90-400-12x8.5x3-(0.5)-2000 .....	Page 31
POF-D/90-700-d4-(1.1)-2000 .....	Page 32
POF-D/90-800-12x8x3-(0.5)-2000 .....	Page 32
POF-D/90-1500-31x13.5x4.2-(1.1)-2000 .....	Page 33
POF-D/90-CSC-31x13.5x4.2-(2.2x11)-2000 .....	Page 34

##### Through-beam optical fibers „simplex“

POF-SPX2-d2.2-(1.0)-(length) .....	Page 34
------------------------------------	---------

#### Optical Frontend:

##### Optical frontend suitable for the "simplex" optical fibers

POF-SPX1-d2.2-(1.0)-(length) respectively

POF-SPX2-d2.2-(1.0)-(length)

KL-M18/20-SPX .....	Page 35
---------------------	---------

#### Accessories:

##### Reduction sleeves (included with the optical fiber)

POF-SLV-2.2/1.1 .....	Page 36
-----------------------	---------

POF-SLV-2.2/1.3 .....	Page 36
-----------------------	---------

##### Fiber cutting tool

POF-CUTTER .....	Page 37
------------------	---------